

CLARK-DRAIN



THE DRAINAGE COMPANY

CHAMBER ACCESS SYSTEMS



Defence | Security | Highways | Utilities |
Telecommunications | Construction | Rail | Docks

Clark-Drain leads the way as a UK manufacturer of chamber access systems

Clark-Drain is a leading innovator of chambers and covers delivering cable/utility access and network protection solutions. Central to their design is a focus on customer needs. It is why we supply them to a customer's precise requirements, as complete chamber access systems, ready to go in the ground, to make them easy to install and to provide the flexibility required for different installations.



Why use a Clark-Drain Chamber Access System?



ONE SUPPLY SOURCE FOR ALL YOUR NEEDS

- Supplied to a customer's precise requirements, complete with galvanised steel, ductile iron or composite access covers, chamber furniture, i.e. bearer bars, step irons, etc., all accessories and pre-configured duct holes (dependent on product choice). Cable management is included pre-installed
- We provide drawings to specification which customers can amend and sign off so that we can deliver the precise solution for your installation



COST EFFECTIVE

- A single source of supply, delivered on time and in full, reduces the time and cost associated with managing different suppliers, e.g. inventory, transport to site, long delivery lead-in times which can cause project hold-ups, etc.
- Complete chamber solutions are easy to install reducing the labour and equipment required and the need for specialist skills
- Installation of the chamber and pipe fittings will take approximately half an hour when the chamber is installed as a complete unit



STRONG

- Strong in-house focus on material technology and technical design
- Design focused on whole life product strength and durability



VERSATILE

- Chamber and cover variants for footway and carriage/roadway installations
- Multiple clear opening sizes provide wide product choices
- Applications range from defence organisations looking for data security; general construction of fibre optic and broadband CATV networks; water companies looking to protect assets, e.g. pumping systems and valves; and highways and pavements, for accessing motorway communications, traffic signalling, street lighting and dockyards
- Plain-sided and 'multiple' duct entry configurations are available for:- 'virgin' sites; overbuilding on live networks; or bespoke build. Chambers are comprised of 150mm deep ring sections



QUALITY MANUFACTURE

- Manufactured in accordance with BS EN ISO 9001:2008 Quality Management Systems
- The chamber bellmouths are designed to be Mandrel test friendly
- Chambers are tested to BS EN 124 B125 (12.5T), D400 (40T) and E600 (60T) loading
- Covers and frames are compliant to BS EN 124 and Fabricated Access Covers Trade Association (FACTA) guidelines
- Modular twin wall chambers are approved by the Ministry of Defence JSP 604 PART 2 - Regulations for the Installation of Information Communication Technology
- Factory fitted step irons are designed, manufactured and tested to EN13101:2002



HEALTH AND SAFETY

- Manual handling – Strong chamber structure makes it easy to handle and assemble during installation
- Minimal flexing and a slip-resistant tread pattern on the step irons reduces operator uncertainty during access



GREEN CREDENTIALS

- One stop supply means more efficient use of transport
- Chambers are made from 100% recycled polypropylene

Versatility as standard

Safeguarding communication and utility networks

With the aim of contributing to network access and security, our chamber systems are designed and engineered to accommodate fibre optic networks and broadband CATV networks in footways and carriageways as well as other underground assets such as electric cables, pumping systems and valves, traffic light systems and street lighting, etc., depending on your product choices.

Stability

Chambers are moulded in recycled polypropylene and retain exceptional strength to weight properties. Excellent durability and loading performance results from a lattice structure inside the chamber walls, with each moulded segment locking tightly together to form 150mm ring sections, secured by internal wall bearer bars to add further stability during transit, installation and use.

Flexible design

A wide choice of chamber systems are available with a variety of pre-determined duct entry patterns, plain-sided for bespoke drilling requirements and flat panel options.

High quality, dependable products

Our heavy duty chambers are manufactured under a certified BS EN ISO 9001:2015 Quality Management System and are tested up to BS EN 124 E600 loading whilst our covers and frames are compliant to FACTA and BS EN 124. Coupled with this is a long product life, which is further enhanced by the chambers' resistance to ground acids, alkalines, petrol and diesel.

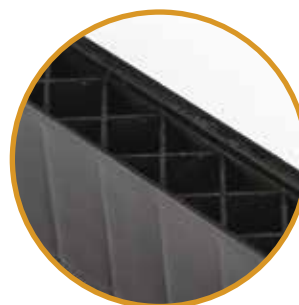

A strong uniform lattice structure inside the chamber walls reduces flexing and provides a firm structure for easy manual handling and assembly.



Moulded duct aperture will accommodate 96mm and 110mm bellmouth and cap.

Galvanised steel internal bearer bars stabilise the chamber wall and prevent ring movement.

Factory fitted step irons have a slip-resistant tread pattern and are designed, manufactured & tested to EN13101:2002. Due to the lattice strength structure within the chamber walls there is minimal flexing on the step irons which prevent operator uncertainty during access.

MANDREL TEST

To verify the integrity of the duct installation, Mandrel testing will ensure that the minimum acceptable internal diameter of the duct entries is maintained throughout. The chamber bellmouths are designed to be Mandrel test friendly.



Duct-entries can be supplied in various configurations and sizes.

The thickness of the chamber walls have been optimised to provide excellent cover seating and good interaction with the bedding material.

Tested up to E600 (60T) load rating.

Industry Applications



Defence – Data cable protection



Highways – Street lighting, traffic signals and motorway communications



Utilities – Cables (electricity and telecommunications), gas, water, etc.



Construction – General building of underground utilities



Defence and Security – Security solutions for defence and prisons



Rail – Non track-side cabling

Commitment to Quality

Our access systems are manufactured under a certified BS EN ISO 9001:2015 quality management system. Further assurance of quality is gained from the relevant European and British performance specification under the prestigious british standard kitemark and compliance with relevant industry specific regulations.

The following standards are applied to our chambers and access covers:

ISO 9001:2015

All work is carried out under the international quality standard, BS EN ISO9001:2015 that governs our product manufacture. Our whole team is committed to the principles of Total Quality Management.

BS EN 124

Our ductile iron covers and frames are BSI Kitemark Certified to BS EN 124-2:2015 E600, D400, C250 and B125 load rating classification.

FACTA

FACTA guidelines are used in the specification of our fabricated steel access covers as an industry standard to ensure high quality and fitness for purpose.

JSP 604 PART 2

Our chambers, covers and frames are manufactured in accordance with the Ministry of Defence JSP 604 Part 2 – Regulations for the Installation of Information Communication Technology.

UVDB Verify

Clark-Drain has Category A status with The Utilities Vendor Database (UVDB) Verify scheme against key criteria such as Health and Safety, Environmental controls & procedures and quality.

HA 104/09

Many of our covers are designed to comply with the Highways England 'Design Manual for Roads' for low and high risk areas.



KM 98709



FM 86830



What makes us different?

“We install fully compliant infrastructure which meets the directives within the Joint Service Publications, passes the concise detail expected within the Engineering Change Request procedure and that of the Site Coordinating Design Authority (SCIDA)”

Babcock

“Clark Drain focus their design on the needs of their customers’ network security requirements to ensure easy access and sound protection to the sub-terrain network routes”

AVC Digital

“Every time we have stipulated Clark-Drain chambers we have achieved full compliance sign off. Having a ‘one stop shop’ for technical assistance, product compliance and ease of installation has given us the confidence to recommend Clark-Drain to all of our contractors”

H S Infra

“Clark Drain have been, and continue to be, one of Aspire Defence Capital Works main suppliers of JSP compliant OSP chambers. They continue to look at improving, what are already quality products, so that we can deliver the CIS Passive Infrastructure for the MOD”

Aspire Defence

Chamber access security solutions



CD2490D1424D9F

FEATURES

- Twin wall design with strong uniform lattice structure
- Manufactured from recycled material
- Flexibility during installation suits new or existing networks or top section adjustment

APPLICATION

- Suitable for use in paths and grass areas
- MOD approved
- 2.5T (slow moving) wheel load/up to 10T (slow moving) GPW

FACTA AAA

Product code	Clear opening (mm)	Depth (mm)	Duct size (mm)	Depth of lid (mm)	Cable management			Total weight (kg)
					Wall bearers	Bearer arms	Locking pins	
CD2490D1424F	600 x 600	900	Plain-sided	88	2	2	2	108
CD2490D1424D9F	600 x 600	900	96	88	2	2	2	107
CD2490D1424D1F	600 x 600	900	110	88	2	2	2	106

Options:

- Security
- Non-security
- Cover locking screws for additional security
- Plain-sided, bespoke drilling or military specification
- Bespoke chamber sizes available on request
- Keyed alike or keyed to differ padlocks (CD PL350 padlock sold separately)
- Varied duct configurations

FEATURES

- MOD 'Pheon' symbol laser-cut into cover for permanent identification
- Integral security plate with case-hardened hasp (to 0.5mm depth) to deter unauthorised access to manhole/chamber
- Integral vertical tabs to secure frame to chamber
- Integrated lifting key holes (CD553 or CD553L lifting keys required, available separately)



CD1424/SEC
Lug bolts not shown, but are included



CD2496DI445F

FEATURES

- Twin wall design with strong uniform lattice structure
- Manufactured from recycled material
- Flexibility during installation suits new or existing networks or top section adjustment

APPLICATION

- Suitable for use in paths and grass areas
- MOD approved
- 2.5T (slow moving) pneumatic wheel load/up to 10T (slow moving) GPW

FACTA AAA

Product code	Clear opening (mm)	Depth (mm)	Duct size (mm)	Depth of lid (mm)	Cable management				Total weight (kg)
					Wall bearers	Bearer arms	Locking pins	Step irons	
CD2496DI445F	1200 x 600	900	Plain-sided	80	4	4	4	2	172
CD2496DI445DIF	1200 x 600	900	110	80	4	4	4	2	169
CD2496DI445D9F	1200 x 600	900	96	80	4	4	4	2	170

Options:

- Security
- Non-security
- Cover locking screws for additional security
- Plain-sided, bespoke drilling or military specification
- Bespoke chamber sizes available on request
- Keyed alike or keyed to differ padlock (CD PL350 padlocks sold separately)
- Varied duct configurations

FEATURES

- 180° opening ensures hidden access to clear opening with tamper proof hinges
- Concealed padlock box with hardened hasp staple
- MOD 'Pheon' symbol laser-cut into cover for permanent identification
- Integral vertical tabs to secure frame to chamber
- Integrated lifting key holes (CD553 or CD553L lifting keys required, available separately)



CD1445/SEC



CD2498E1446F

FEATURES

- Twin wall design with strong uniform lattice structure
- Manufactured from recycled material
- Flexibility during installation suits new or existing networks or top section adjustment

APPLICATION

- Suitable for use in paths and grass areas
- MOD approved
- 2.5T (slow moving) pneumatic wheel load/up to 10T (slow moving) GPW

FACTA AAA

Product code	Clear opening (mm)	Depth (mm)	Duct size (mm)	Depth of lid (mm)	Cable management				Total weight (kg)
					Wall bearers	Bearer arms	Locking pins	Step irons	
CD2498E1446F	1500 x 750	1050	Plain-sided	80	4	4	4	3	234
CD2498E1446D1F	1500 x 750	1050	110	80	4	4	4	3	230
CD2498E1446D9F	1500 x 750	1050	96	80	4	4	4	3	230

Options:

- Security
- Non-security
- Cover locking screws for additional security
- Plain-sided, bespoke drilling or military specification
- Bespoke chamber sizes available on request
- Keyed alike or keyed to differ padlock (CD PL350 padlock sold separately)
- Varied duct configurations

FEATURES

- 180° opening ensures hidden access to clear opening with tamper proof hinges
- MOD 'Pheon' symbol laser-cut into cover for permanent identification
- Concealed padlock box with hardened hasp staple
- Integral vertical tabs to secure frame to chamber
- Integrated lifting key holes (CD553 or CD553L lifting keys required, available separately)



CD446/SEC
Lug bolts not shown, but are included



CD2490D777SD9F

FEATURES

- Twin wall design with strong uniform lattice structure
- Manufactured from recycled material
- Flexibility during installation suits new or existing networks or top section adjustment

APPLICATION

- Suitable for use in paths and grass areas
- MOD approved
- B125 (12.5 tonnes) wheel load rating

B125								
Product code	Clear opening (mm)	Depth (mm)	Duct size (mm)	Depth of lid (mm)	Cable management			Total weight (kg)
					Wall bearers	Bearer arms	Locking pins	
CD2490D777SD9F	600 x 600	900	96	40	2	2	2	115
CD2490D777SD1F	600 x 600	900	110	40	2	2	2	115

Options:

- Security
- Non-security
- Cover locking screws for additional security
- Plain-sided, bespoke drilling or military specification
- Bespoke chamber sizes available on request
- Keyed alike or keyed to differ padlock (CD PL350 padlock sold separately)
- Varied duct configurations

FEATURES

- Integral steel security plate with case-hardened hasp
- Cast-in Pheon logo
- Integral fixings secure frame to chamber walls
- BSI Kitemark Certified to BS EN124
- Integrated lifting key holes (CD553 or CD553L lifting keys required, available separately)



CD777 KMB/SEC



CD2496D69ISDIF

FEATURES

- Twin wall design with strong uniform lattice structure
- Manufactured from recycled material
- Flexibility during installation suits new or existing networks or top section adjustment

APPLICATION

- Suitable for use in pavements
- MOD approved
- B125 (12.5 tonnes) wheel load rating

B125									
Product code	Clear opening (mm)	Depth (mm)	Duct size (mm)	Depth of lid (mm)	Cable management				Total weight (kg)
					Wall bearers	Bearer arms	Locking pins	Step irons	
CD2496D69ISF	1200 x 600	900	Plain-sided	40	4	4	4	2	185
CD2496D69ISDIF	1200 x 600	900	110	40	4	4	4	2	184
CD2496D69ISD9F	1200 x 600	900	96	40	4	4	4	2	185

Options:

- Security
- Non-security
- Cover locking screws for additional security
- Plain-sided, bespoke drilling or military specification
- Bespoke chamber sizes available on request
- Keyed alike or keyed to differ padlock (CD PL350 padlock sold separately)
- Varied duct configurations

FEATURES

- Slide-out ductile iron covers to reduce manual-handling concerns
- Fitted with 2-part security plate assembly requiring only 1 padlock
- Case-hardened hasp
- Integral Pheon logos
- Removable center beam for full pit access
- BSI Kitemark Certified to BS EN124
- Integrated lifting key holes (CD553 or CD553L lifting keys required, available separately)

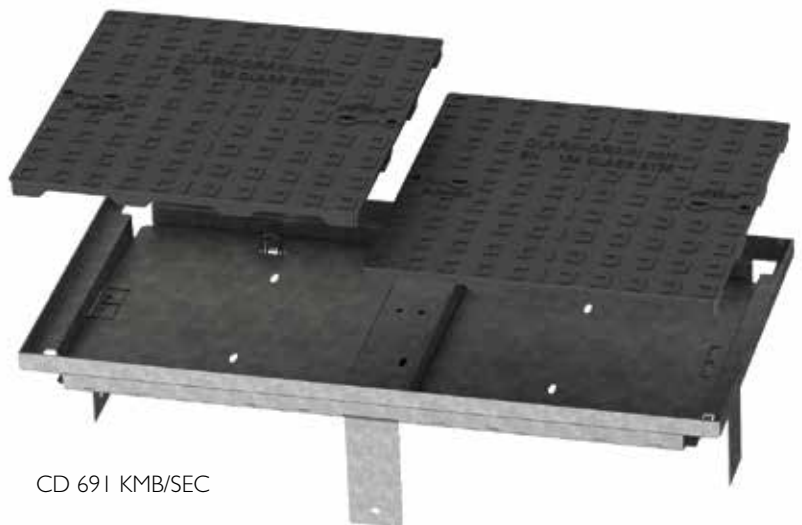

CD 69I KMB/SEC



CD2490D701HF

FEATURES

- Twin wall design with strong uniform lattice structure
- Manufactured from recycled material
- Flexibility during installation suits new or existing networks or top section adjustment

APPLICATION

- Suitable for use in carriageways
- MOD approved
- D400 (40 tonnes) wheel load rating
- HA 104/09 compliant

D400								
Product code	Clear opening (mm)	Depth (mm)	Duct size (mm)	Depth of lid (mm)	Cable management			Total weight (kg)
					Wall bearers	Bearer arms	Locking pins	
CD2490E701HF	600 x 450	1050	Plain-sided	100	2	2	2	126
CD2490D701HF	600 x 450	900	Plain-sided	100	2	2	2	120

Options:

- Security
- Non-security
- Cover locking screws for additional security
- Plain-sided, bespoke drilling or military specification
- Bespoke chamber sizes available on request
- Keyed alike or keyed to differ padlock (CD PL350 padlock sold separately)
- Varied duct configurations



CD 701H KMD/SEC
Lid removed to show security plate

FEATURES

- Cast-in Pheon identification is integral to the body of the cover
- Removable inner security plate (once padlock has been removed)
- Non-rock 3 point suspension cover
- Solid flange area improves load transfer to reduce stress on bedding
- BSI Kitemark Certified to BS EN124
- Integrated lifting key holes (CD552 or CD552L lifting keys required, available separately)



CD2497E693HSF

FEATURES

- Twin wall design with strong uniform lattice structure
- Manufactured from recycled material
- Flexibility during installation suits new or existing networks or top section adjustment

APPLICATION

- Suitable for use in carriageways
- MOD approved
- D400 (40 tonnes) wheel load rating
- HA 104/09 compliant

D400									
Product code	Clear opening (mm)	Depth (mm)	Duct size (mm)	Depth of lid (mm)	Cable management				Total weight (kg)
					Wall bearers	Bearer arms	Locking pins	Step irons	
CD2497E693HSF	1200 x 675	1050	Plain-sided	100	4	4	4	3	301
CD2497D693HSD1F	1200 x 675	900	110	100	4	4	4	2	287
CD2497D693HSD9F	1200 x 675	900	96	100	4	4	4	2	287
CD2497E693HSD1F	1200 x 675	1050	110	100	4	4	4	3	301
CD2497E693HSD9F	1200 x 675	1050	96	100	4	4	4	3	301

Options:

- Security
- Non-security
- Cover locking screws for additional security
- Plain-sided, bespoke drilling or military specification
- Bespoke chamber sizes available on request
- Keyed alike or keyed to differ padlock (CD PL350 padlock sold separately)
- Varied duct configurations

FEATURES

- Cast-in Pheon identification is integral to the body of the cover
- Non-rock 3 point suspension
- Fitted with 2-part security plate assembly requiring one padlock
- BSI Kitemark Certified to BS EN124
- Integrated lifting key holes (CD552 or CD552L lifting keys required, available separately)



CD693H KMD/SEC



CD2498E695HSF

FEATURES

- Twin wall design with strong uniform lattice structure
- Manufactured from recycled material
- Flexibility during installation suits new or existing networks or top section adjustment

APPLICATION

- Suitable for use in carriageways
- MOD approved
- D400 (40 tonnes) wheel load rating
- HA 104/09 compliant

D400									
Product code	Clear opening (mm)	Depth (mm)	Duct size (mm)	Depth of lid (mm)	Cable management				Total weight (kg)
					Wall bearers	Bearer arms	Locking pins	Step irons	
CD2498E695HSF	1500 x 750	1050	Plain-sided	100	4	4	4	3	428
CD2498E695HSD1F	1500 x 750	1050	110	100	4	4	4	3	415
CD2498E695HSD9F	1500 x 750	1050	96	100	4	4	4	3	416

Options:

- Security
- Non-security
- Cover locking screws for additional security
- Plain-sided, bespoke drilling or military specification
- Bespoke chamber sizes available on request
- Keyed alike or keyed to differ padlock (CD PL350 padlock sold separately)
- Varied duct configurations



CD695H KMD/SEC

FEATURES

- Integral cover hinge stops to prevent accidental closing and enabling opening in confined spaces
- 100° min safe cover-open resting angle
- Fitted with 2-part security plate assembly requiring one padlock
- BSI Kitemark Certified to BS EN124
- Integrated lifting key holes (CD552 or CD 552L lifting keys required, available separately)

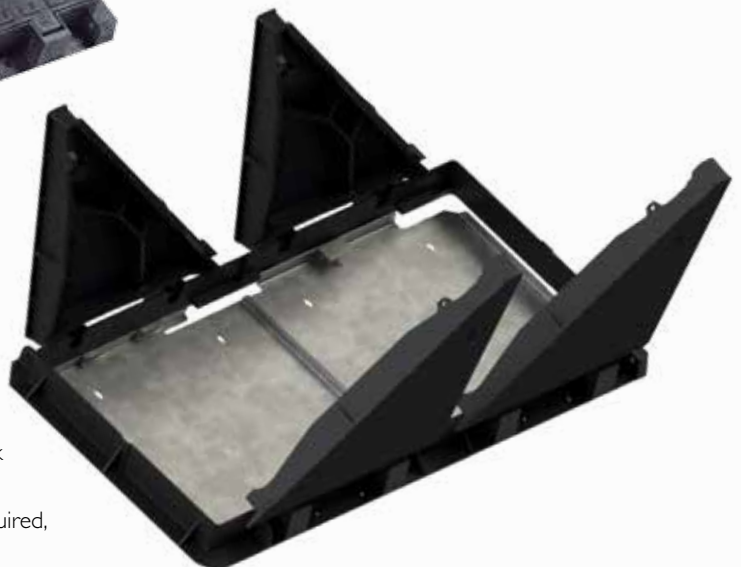



Chamber Access System

Traffic signals, street lighting and communication networks

Lightweight modular systems are used frequently in construction, especially for utility installations, to ease and protect access to ducting and underground services.

Project suitability

- Pavements
- Road verges
- Street lighting
- Traffic signalling

Whether a new build or renewal project, our modular panel system can accommodate utility access construction for various applications:

- Electricity HV/LV
- Cable TV/CCTV
- Gas
- Water
- Telecommunications

How it works

The natural honey comb design within a concrete surround enables installation to be completed efficiently and effectively so that the ducting can be installed to meet the Highway Regulations of minimum duct cover:

Reliability through material choices and design is necessary to ensure optimal strength, hence the honeycomb pattern combining natural light-weight construction with high-strength qualities.

The system uses panel sections which clip together for easy site assembly and to aid alignment for stacking.

There are also trepanned locations to accept 63mm, 110mm, 120mm and 160mm diameter duct with a 178mm indentation for larger specifications. These are designed to help guide the operator and installer to accommodate various duct types.

Specification considerations

- Exceptionally light
- Compatible with NJUG guidelines
- Panels are available in 300mm, 450mm and 600mm widths (300mm high)
- The chamber is designed to support the Specification for Highway Works relating to the minimum depths of excavation for cables laid under verges, footways or open ground
- Many manhole applications require manhole lids to be non-conductive. For Telecommunication and electrical utility applications the covers are non-ferrous composite material. Covers are black in colour and marked with "Traffic signals" and "Street Lighting" badging
- Integral lifting keyholes
- A slip resistant cover with a PSRV value of 60 suits both low risk pedestrian traffic, cyclists or equestrian use and potentially high risk sites, specified (Part 5 HA 104/09)
- Covers have a B125 (12.5 tonnes) load rating classification
- All quality systems and inspection procedures comply with BS EN ISO 9001: 2015



Ease of use

- Trepanned entry points to accept electricity and utility duct sizes 63mm-160mm
- 178mm duct entry point indentation guide

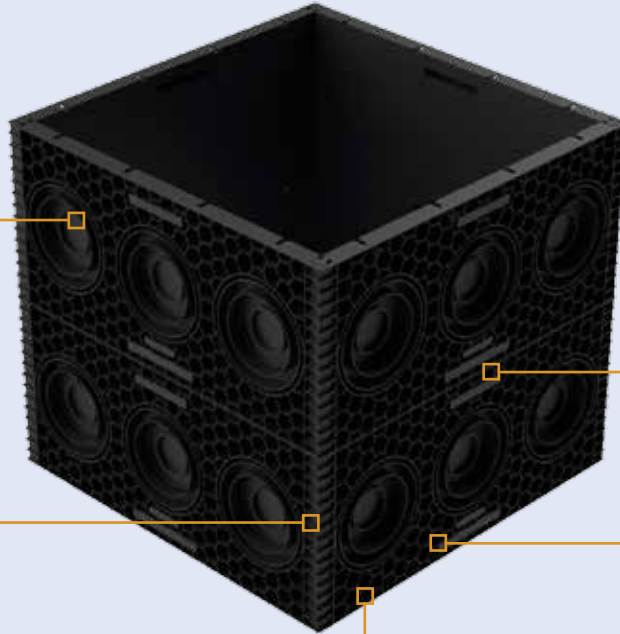

Stability

- Universal T-slot corner connection for ease of assembly and high strength joints

Ease of installation

- Sections clip together for easy site assembly and to aid alignment for stacking

Green credentials

- Panels are injection moulded in 100% recycled Polypropylene

Strength + Durability

- The honey comb internal wall provides natural structural strength

CHAMBER ACCESS

Easy assembly of components to clear opening sizes.

- 300mm x 300mm
- 450mm x 300mm
- 450mm x 450mm
- 600mm x 450mm
- 600mm x 600mm

Typical Installations

Panels are 300mm depth, with interlocking features which allow multiple panels to be assembled, easily stacked and installed to the recommended depths and positioning of underground utilities

Product code	Panel width (mm)	Panel depth E (mm)	Total weight (kg)
CD251	300	300	0.6
CD252	450	300	0.8
CD253	600	300	1.0

Composite covers and frames

The range of Clark-Drain composite covers provide the highest levels of slip resistance to support pedestrian safety with PSRV values in line with HA104 guidelines.

Security

- Captive cage nut for fixing lid to frame using 2 bolts per lid (supplied)

Safety

- Slip-resistant cover for sites predominantly used by pedestrian, cyclists and equestrian traffic follows HA 104 guidelines
- Slide out cover action aids manual handling

Pit identification

- Badging as standard 'TRAFFIC SIGNALS'/'STREET LIGHTING'

Ease of maintenance

- Cover cap for keyholes to reduce ingress of debris and water

Future proofing

- Multi-purpose louvre frame depth accommodates 65mm block paving within a 70mm upstand and solid top composite cover

Stability

- 12mm bolt for fixing frame to chamber panel (bolts not included)

Product sizes

Access covers are specified by their clear opening dimensions (A x B), depth (E) and overall size (C x D). The product sizes indicated in the CAD drawing are referenced in the table

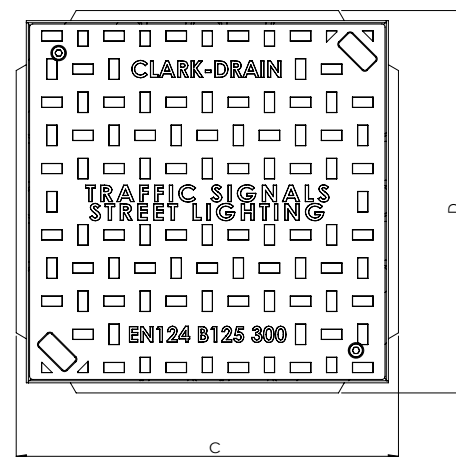
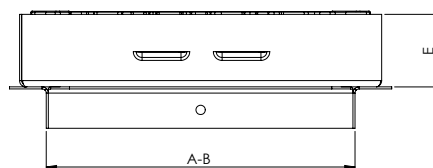

Product code	Load rating	Description	Clear opening size (mm) A x B	Overall size (mm) C x D	Depth of upstand (mm) E	Total weight (kg)
CD261/SF	B125	Composite cover with galvanised steel frame	300 x 300	369 x 369	70	10
CD262/SF	B125	Composite cover with galvanised steel frame	450 x 300	519 x 369	70	13.5
CD263/SF	B125	Composite cover with galvanised steel frame	450 x 450	519 x 519	70	17
CD264/SF	B125	Composite cover with galvanised steel frame	600 x 450	669 x 519	70	21.5
CD265/SF	B125	Composite cover with galvanised steel frame	600 x 600	669 x 669	70	28



Installation Guide

CLARK-DRAIN B125 MODULAR CHAMBER INSTALLATION GUIDELINES

THESE ARE INTENDED AS GUIDELINES ONLY – IF IN DOUBT, SEEK ADVICE.

ALWAYS TAKE CARE WHEN USING HAND AND POWER TOOLS AND WEAR PPE.

Notes before starting works:

- a) Clark-Drain B125 modular chamber panels are supplied with a selection of pre-trepanned duct entries on the outside faces of the panels, and markings/pilot drill guides on the inside faces for further duct entry size and spacing options. All are marked with the sizes of either 63mm, 110mm, 120mm, 162mm or 178mm, although the exact selection available depends on the panel size (300, 450 or 600mm) concerned.

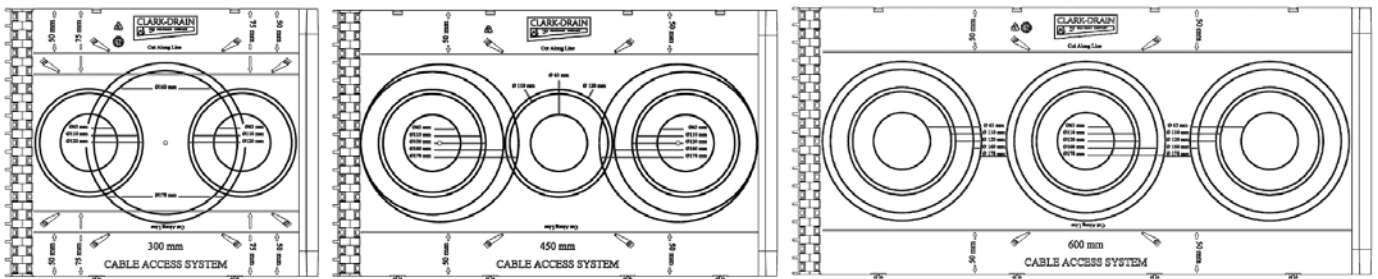

- b) Once the required duct entry sizes and configuration is decided, they should be drilled using an appropriately sized hole saw. Duct entries should **not** be drilled at positions other than those that are pre-marked on the chamber panel.
- c) All ducting should enter at 90° to the chamber wall.
- d) Chamber panels are supplied unassembled and can be used in any configuration of the 300, 450 and 600mm versions available to create either 300x300, 450x300, 450x450, 600x450 or 600x600 chambers.
- e) Standard panel depth is 300mm, and panels can be stacked on top of each other and clipped together to create chamber depths of 300, 600, 900 or 1200mm. It is not recommended to exceed 1200mm depth.
- f) Should fine-tuning of chamber depth be required, each chamber panel is moulded with an integral cutting line guide at 50 and/or 75mm from the top or bottom edge. A hand saw can be used to remove the required amount and adjust the finished height of the chamber installation.

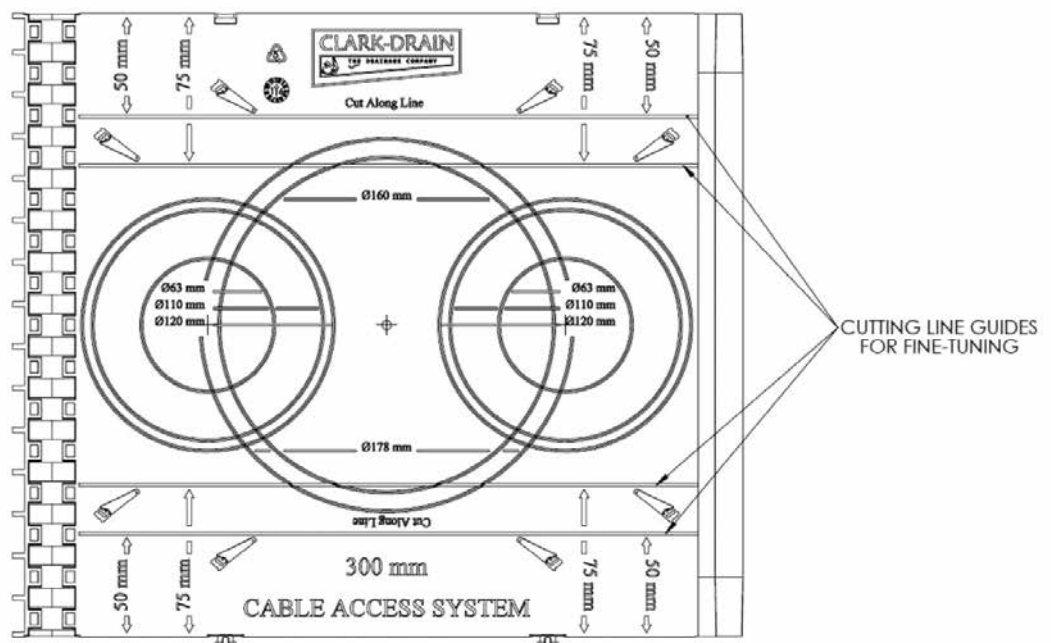

Installation:

1. Mark out the area where the pit is to be excavated, allowing a minimum of 125mm (or more to allow space to work as needed) around the full perimeter of the chamber for backfilling.
2. Within the marked area, excavate from finished surface level to the total depth of the chamber, plus the depth of the concrete base, plus the depth of the access cover and frame.
3. Once the pit has been excavated, compact the base then install position the anchor iron if required in its intended position before pouring a concrete base to form the foundation of the chamber. The concrete used for the base should be of at least C20 grade and be at least 100mm thick. While the concrete is still wet it is recommended that the bottom ring of the chamber be set into it by approx. 25mm
4. Assembly of the chamber panels to form full rings is simple and merely requires each male/female corner joint to be slid together as shown:

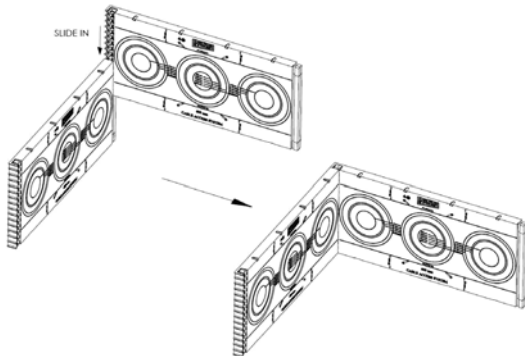

5. When the first ring is assembled and in position finish the base using a float and trowel to achieve an even surface.
6. The remaining sections of the chamber can then be installed on top of the base ring, in the sequence shown:

STEP 1

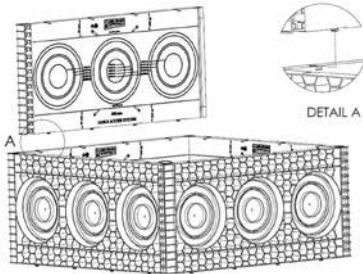

STEP 2

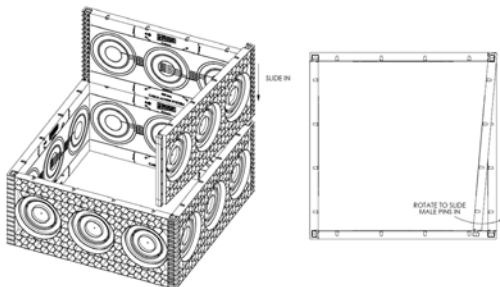

STEP 3

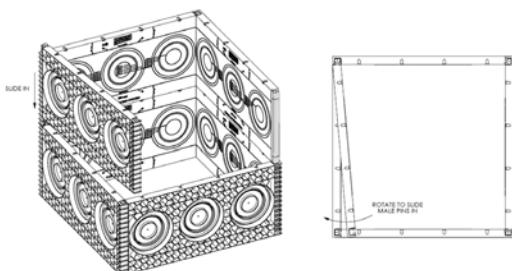

STEP 4

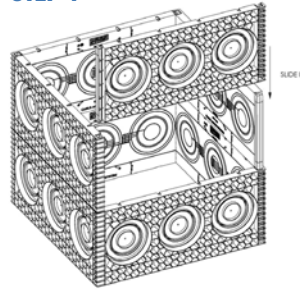

STEP 5

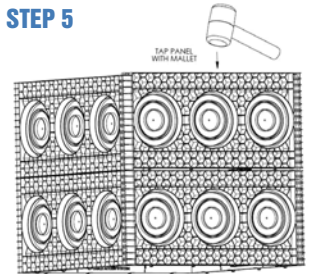

Repeat for each additional chamber layer.

7. Prior to back-filling around the chamber, the inside walls **must** be fully and substantially braced to avoid the walls bowing inwards during back-filling and compaction. This bracing should only be removed when the chamber installation is complete and all concrete used has fully cured.
8. For all applications the back-fill should be concrete of at least C20 grade. Back-fill in 300mm maximum layers and allow to cure before applying the next layer. Chambers installed in turfed or soft-standing areas should also have a concrete ring formed and set around the frame of the access cover of at least 75mm wide x 50mm deep to prevent damage to the access cover by non-road vehicles (e.g. lawn-mowers) and/or long-term sinking issues.
9. When the back-filling is complete and concrete has fully cured the access cover and frame can be fitted directly on top of the chamber; and attached/secured using the fixing holes provided on all 4 sides of the frame skirt.

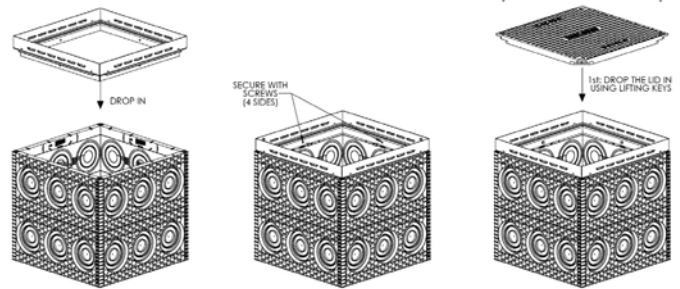

Example installation diagrams (600x600 C/O shown):

FOR SOFT STANDING AREAS

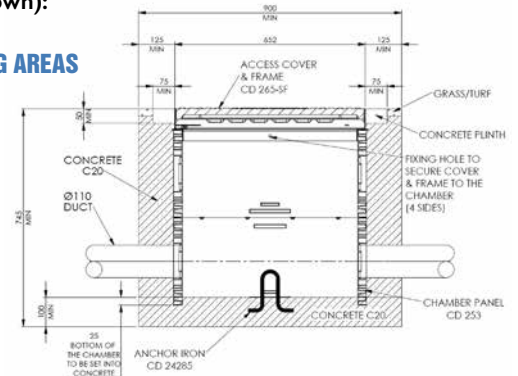

FOR HARD STANDING AREAS

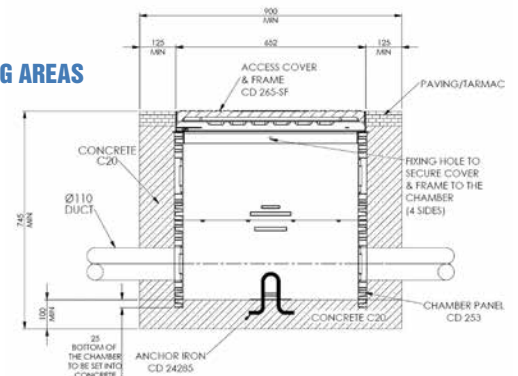

Installation Guidelines for Clark-Drain Modular Chamber System

THESE ARE INTENDED AS GUIDELINES ONLY – IF IN DOUBT, SEEK ADVICE.
ALWAYS TAKE CARE WHEN USING HAND AND POWER TOOLS AND WEAR PPE

NOTES BEFORE STARTING WORKS:

- A** All Clark-Drain modular chambers are supplied with a pre-determined configuration of duct entries along with a selection of 96mm or 110mm bellmouths, and universal blanking caps.
 - i. The blanking caps should be used on all unused duct entries, fitted on the outside wall of the chamber, to prevent back-fill from entering during subsequent installation.
 - ii. Bellmouths should be fitted on the inside as required for all duct entries.
 - iii. Should additional quantities of bellmouths or blanking caps be required these can be purchased separately (product codes CD 24281/96, CD 24281/110 and CD 24282).
- B** Should additional duct entries be required the chamber walls can be drilled with a hole-saw at an appropriate position, ideally along the same horizontal plane and without cutting across any joint lines if possible. Please note: breaching too many joint lines while drilling bespoke duct entries may compromise the chamber wall strength.
- C** All ducting should enter at 90° to the chamber wall.
- D** Chamber depth can be increased using additional ring sections, purchased separately. Each ring increases the chamber depth by 150mm, and must be secured to the adjacent ring by use of link plates provided. When adding rings to increase chamber depth, please remember to purchase and fit additional step-irons (product code CD 24840) as needed. We recommend at least one step every third ring (i.e. every 450mm).

INSTALLATIONS:

- 1** Mark out the area where the pit is to be excavated, allowing a minimum of 150mm (or more to allow space to work as needed) around the full perimeter of the chamber for backfilling and compaction.
- 2** Within the marked area, excavate from finished surface level to the total depth of the chamber, plus the depth of the concrete base, plus the depth of the access cover and frame (including a small allowance for bedding mortar).
- 3** Once the pit has been excavated, compact the base then install/position the anchor iron and/or sump unit with soakaway if required in their intended positions before pouring a concrete base to form the foundation of the chamber. The concrete used for the base should be of at least C20 grade and be at least 150mm thick. While the concrete is still wet it is recommended that the bottom ring of the modular chamber be set into it by approx. 25mm. To facilitate this, Clark-Drain modular chambers are supplied with the bottom ring easily detachable by removal of the relevant cable bearer bracket fixings, if fitted, or by removal of the plastic welds that hold the bottom ring to the one above.
- 4** When the bottom ring of the chamber is in position finish the floor using a float and trowel to achieve an even surface that is sloped slightly towards the sump (if installed).
- 5** The remaining ring sections of the chamber can then be installed on top of the base ring, securing the two together with the fixings provided, and ensuring the ducting is fitted in the relevant duct entry holes and trimmed to the correct length.
- 6** Prior to back-filling around the chamber, the inside walls must be braced adequately to avoid the walls bowing inwards. This bracing can be removed when the chamber installation is complete and all concrete used has fully cured. At this point all required bell-mouths should be fitted.
- 7** For FACTA AAA/B125 applications the back-fill can be as-dug material or dry mix concrete. For D400 applications the back-fill must be concrete of at least C20 grade. Back-fill in 300mm maximum layers and where dry mix or concrete has been used allow to cure before applying the next layer. Chambers installed in turfed or soft-standing areas should also have a concrete ring around the frame of the access cover of at least 100mm wide x 75mm deep to prevent damage to the access cover by non-road vehicles (e.g. lawn-mowers) and/or long-term sinking issues.
- 8** When the back-filling is complete and any concrete used has fully cured the access cover and frame can be fitted as per normal procedure. Resin-based bedding mortar between the access cover frame and chamber top is recommended for FACTA AAA/B125 applications, and a necessity for D400 applications (as per standard industry practice).

Example installation diagrams

D400 CHAMBER INSTALLATION

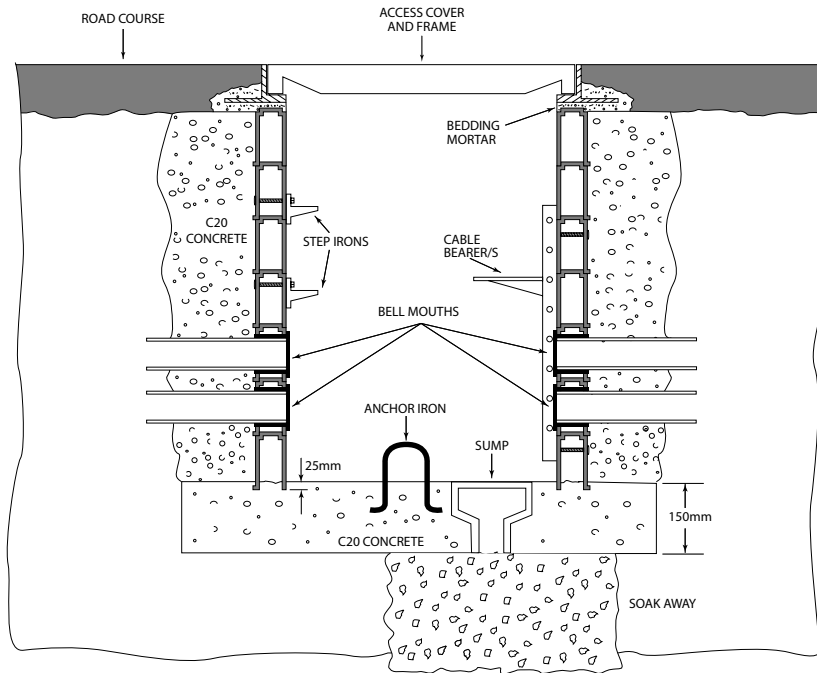

FACTA E / E600

FOR FACTA E / E600 INSTALLATIONS THE GUIDELINES ABOVE FOR D400 INSTALLATIONS SHOULD BE FOLLOWED, WITH THE FOLLOWING EXCEPTIONS:

- 1 Back-fill surround width around the full perimeter of the outside of the chamber should be 250mm minimum.
- 2 The thickness of the concrete base should be 250mm minimum.
- 3 Concrete grade used for back-fill and base should be C30 minimum.
- 4 Where the manhole cover being used is intended to be directly sited on top of the chamber, bedding of the manhole cover frame on a thermosetting polymer resin or cement based bedding mortar complying to HA104/09 (Tensile strength of $>5\text{N/mm}^2$ and Compressive strength $>30\text{N/mm}^2$ at 3 hours) is a MUST. Please note that resin based mortars should not be used/applied in wet/rainy conditions as their performance is significantly affected.

FACTA AAA/B125 CHAMBER INSTALLATION

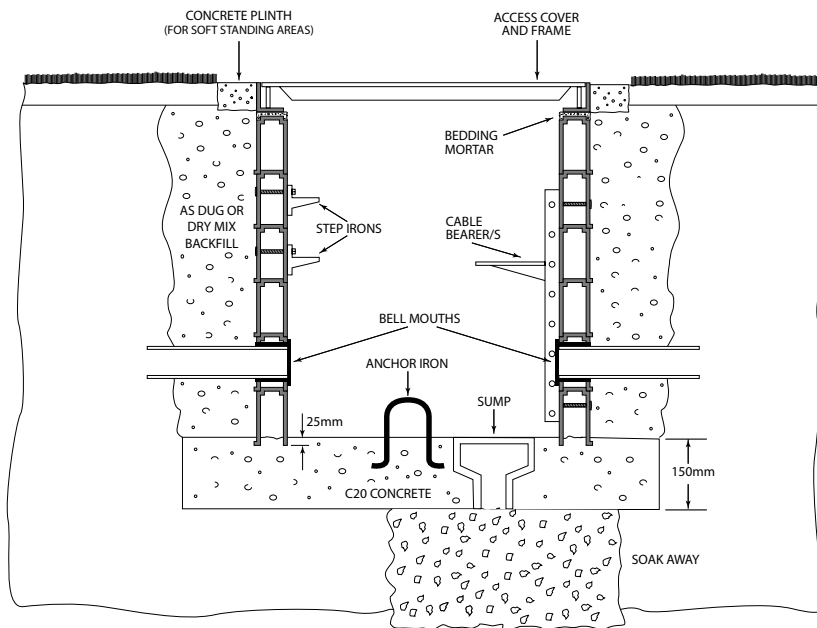

- 5 Where the manhole cover being used is intended for installation on a site-constructed concrete ring beam this must be constructed as directed on separate guidelines (provided with each order) using C30 grade minimum concrete. The manhole cover frame should also be bedded on a thermosetting polymer resin or cement based mortar complying to HA104/09 as per point 4 above. Some covers have integral frame levelling points to aid this part of the installation and setting process. Additionally, any open area around the manhole frame between it and the concrete ring beam should be filled with 45 cube or 40 cylinder concrete during installation using 10mm aggregate.
- 6 Allow time for all concrete and bedding mortar used to fully cure before trafficking the area.

Product Selector

To complement our chambers, a comprehensive range of security and non-security covers and frames are available, manufactured from galvanised steel or ductile iron, depending on the loading required.

Opposite is a selection:

KEY

- Standard product
- Available on request

Options:

Badging, and screw and security locking available on all cover options

	B125 Composite Covers with Steel Frame
	B125 Precinct Steel Covers with 70mm or 100mm internal tray depth (BSI Kitemark Certified to BS EN 124:1994)
	B125 Ductile Iron Covers (BSI Kitemark Certified to BS EN 124:2015)
	D400 Ductile Iron Cover options 100mm depth (Carriageway and non-carriageway) (BSI Kitemark Certified to BS EN 124:2015)
	D400 Ductile Iron Cover options 150mm depth (Carriageway and Non-carriageway) (BSI Kitemark Certified to BS EN 124:2015)
	E600 Ductile Iron Covers (BSI Kitemark certified to BS EN 124: 2015)
	Selection of Steel Pavior/Press/Chequer Plate/Bespoke Covers are available depending on loading/application

Accessories



CD PL350
Padlock Cen Grade 5
(Two types are available 'keyed alike' and 'keyed to differ' as used by the MOD)



CD 24281/110
96 and /110mm Plain Bellmouth
Mandrel tested



CD 24282
Cover Cap for Bellmouth



CD 24840
Step Iron



CD 248208
Cable Bearer Bracket
Various sizes

Chamber clear opening size (mm)

300 x 300	450 x 300	450 x 450	600 x 450	600 x 600	675 x 675	750 x 600	750 x 750	900 x 600	900 x 900	1200 x 600	1200 x 675	1500 x 750	1800 x 675
■	■	■	■	■									
			■	■	■	■	■	■		■	■		■
		■	■	■	■	■		■					
		■	■	■	■	■	■	■	■	■	■	■	■
				■	■	■	■	■			■		■
				■	■						■		
		●	●	●	●	●	●	●	●	●	●	●	●



CD 24830
Cable Bearer
Locking Pin



CD 248105
Wall Cable Bearer
Various sizes



CD 24285
Chamber Anchor Plate



CD 24286
Chamber Sump and Grill

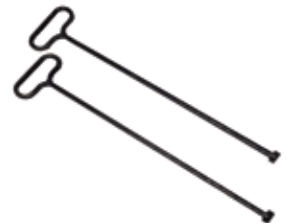

CD 553L
Lifting Keys
Various

Clark-Drain offers a comprehensive range of access covers and drainage products for civils construction projects

DUCTILE IRON COVERS & GULLY GRATINGS

BS EN 124 A15-F900



POLYMER CONCRETE LINEAR DRAINAGE

BS EN 1433 A15-F900



BESPOKE STEEL ACCESS COVERS AND FRAMES

FACTA A-F



Due to our continual development programme, we reserve the right to upgrade products without prior notice. All products must be installed in accordance with Clark-Drain installation guidelines.

CALL +44 1733 765319
FAX +44 1733 246923
EMAIL civils@clark-drain.com

STATION ROAD | YAXLEY | PETERBOROUGH | PE7 3EQ | UNITED KINGDOM



www.clark-drain.com/access-chamber-system

CAT007C